

## Rockland Scientific VMP-250-IR (RDL) operational Checklist (Pre-Cruise, Deployment, and Post-Recovery Procedures)

Instrument Serial Number: \_\_\_\_\_

Cruise / Project: \_\_\_\_\_

Operator(s): \_\_\_\_\_

Date: \_\_\_\_\_

### 1. PRE-DEPLOYMENT PREPERATION

#### General Reminders

- Contact Rockland Scientific at least 4 months prior to deployment if instrument servicing or sensor calibration is required.
- Review the Instrument Manual, especially sections titled "Assembly, Operations & Maintenance" (currently Sections 3-5).
- Inspect all sealing surfaces and O-rings. Replace O-rings if damaged or worn. Rockland recommends replacing O-rings annually regardless of instrument use.
- Ensure all required instrument tools, deployment gear, laptops, cables and spare parts & probes are included with the instrument and are in good condition.
- Rockland recommends shear probes are calibrated annually or more frequently if desired.
- Rockland recommends inspecting and checking probes against [Technical Note TN-067](#).

#### Battery

- Fully charge the instrument (indicated by the green charger light).
- Confirm battery voltage is approximately 16 to 17 V when fully charged.
- Consult the instrument manual (Section 2) to estimate battery run time (typically 6–8 hours, depending on instrument setup and water temperature). Plan to recharge the instrument between casts as needed.

### Probe Port Checks

- Inspect SMC cables for damage or corrosion.
- Confirm each probe port contains greased O-ring & white ferrule.
- Verify O-ring and ferrule are installed in the correct order.

### Electronics Bench Test

- Ensure test probes are installed in the correct port.
- Perform an electronics bench test.
- Use the Bench Test tool in Zissou Software and Rockland Bench Test Checklist to review the resulting p-file and confirm that the instrument electronics are in healthy condition and that all instrument channels are recording normally.

*Reference: See Instrument Manual & [Bench Test Checklist](#) for more information.*

Bench Test Completed Date: \_\_\_\_\_

### Record Probe Serial Numbers

- Confirm probe serial numbers.
- Update setup.cfg file on instrument with correct probe serial numbers & shear probe sensitivity values (from probe calibration report).

S1: \_\_\_\_\_

S2: \_\_\_\_\_

T1: \_\_\_\_\_

T2: \_\_\_\_\_

Additional Sensors: \_\_\_\_\_

## Probe Installation

- Ensure sensor guard is installed prior to installing probes.
- Install probes in correct probe ports (T1, T2, S1, S2) ensuring each probe is properly connected to the SMC cable.

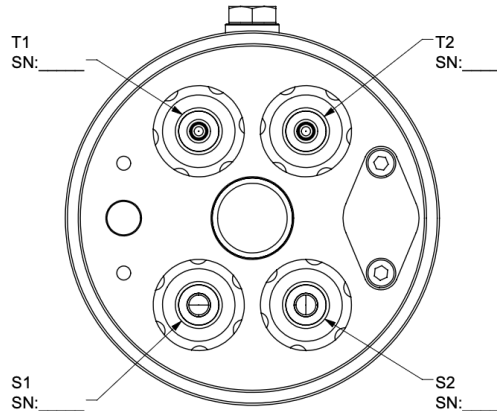

- Verify shear probe orientation (flat sections oriented 90° relative to each other) with S1 oriented towards the ON magnet (x-axis) and S2 oriented to right (Y-axis)..
- Hand-tighten probe holders until snug, tighten an additional 1/8–1/4 turn using probe wrench.
- Don't forget to record or photograph the probe serial numbers.

*Important: Do not overtighten probe holders*

## Final Assembly

- Ensure that all bolts & connectors are secure (consult manual for safe torque rating)
- Assemble the tail section and drag net / brushes.
- Attach instrument to tether or winch using the eye-bolt (we strongly recommend a bowline knot with the tail taped with electrical tape back to the tether).
- optionally install weight collars and / or buoyancy collars - depending on instrument configuration.
- Confirm all mechanical connections are secure and tape down any loose ends.

*Optionally install weights – depending on instrument configuration.*

## 2. PRE-DEPLOYMENT CHECKS (ANYTIME INSTRUMENT ON DECK)

### Start Data Collection

- Turn instrument on using magnetic switch.
- Confirm correct LED startup behavior.

### Final Visual Inspection

- Confirm probes are secure.
- Confirm probe holders are tight.
- Confirm tether attachment is secure.

## 3. DURING-DEPLOYMENT

### Profiling Technique

- Ensure instrument is free falling, by avoiding tension on the line.
- /Maintain one to two coils of rope in the water to ensure free fall of instrument.
- Confirm instrument weight configuration is appropriate, for a target fall speed of approximately 0.7 m/s (most instruments).
- Avoid contacting the bottom by either using:
  - Time of flight technique, using the fall speed to estimate time to reach a certain depth, or;
  - Length of tether technique, marking out the length of the tether required to reach a certain depth.

### Data Verification

- Periodically download data from instrument and review using Zissou Software to verify:
  - The instrument is free falling, at a fall speed near 0.7 m/s and is steady.
  - Stable instrument motion with Incl.X values typically between  $\pm 2$  degrees and a maximum of  $\pm 10$  degrees.
  - No excessive vibration noise, vibrations should be less than  $\pm 500$  raw counts.

Notes: \_\_\_\_\_

### **Occasionally When on Deck**

- Inspect instrument housing and probe tips for damage.

*If issues are observed, take note and replace probes as well as photos & and or contact Rockland ([support@rocklandscientific.com](mailto:support@rocklandscientific.com)).*

### **Battery Monitoring**

- Monitor battery voltage periodically either by:
  - Checking the battery voltage via the Zissou Instrument Dashboard, or;
  - Using a multimeter and the Rockland supplied banana plug adapter.
- Recharge the battery when voltage approaches 15 V, or during pauses in sampling, to maintain sufficient charge.

*Recommended recharge interval: approximately every 6 hours of operation.*

## **4. POST-DEPLOYMENT**

### **Initial Inspection**

- Perform visual inspection of instrument.
- Inspect installed probes for damage.
- Inspect probe ports and cables.

*If issues are observed, take photos & contact Rockland ([support@rocklandscientific.com](mailto:support@rocklandscientific.com))*

### **Instrument Cleaning**

- Rinse instrument and probes with freshwater to remove salt residue.
- Allow instrument to dry completely.
- Dry front bulkhead and probe ports using lint free wipes.

### Probe Removal

- Remove sensing probes.
- Ensure SMC cables and probe ports are dry before sealing. Use lint-free wipes or swabs to remove visible moisture and prevent water from entering deeper into the front bulkhead.
- Dry cables with lint free wipes if necessary.
- Install test probes.

*Note: Water trapped inside probe ports may cause oxidation of SMC cables and degrade signal quality during future deployments.*

### Post-Cruise Maintenance

- Perform maintenance procedures according to Instrument Manual.

Tasks may include:

- Inspect sealing surfaces
- Inspect or replace O-rings
- Clean probe ports
- Inspect cables and connectors

### Pre-Storage Bench Test

- Install test probes.
- Perform electronics bench test.
- Confirm instrument readiness for storage or next deployment.
- Bench Test Completed

Date: \_\_\_\_\_ Operator: \_\_\_\_\_

Additional Notes \_\_\_\_\_  
\_\_\_\_\_  
\_\_\_\_\_  
\_\_\_\_\_